

FMC Technologies

Q32 Plunger Pump Data

700 BHP Continuous Duty (1,000 BHP Intermittent Duty)

Forged ISO Drawing

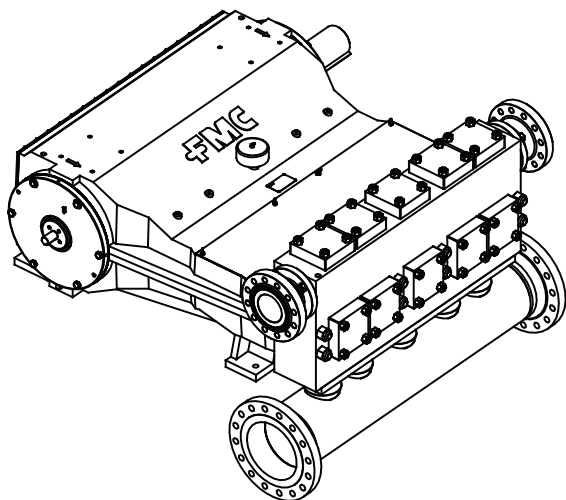

Cast ISO Drawing

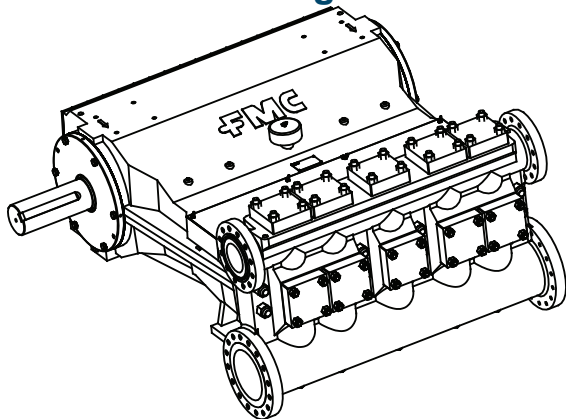

Specifications

Pump Model	Q32
Design Standard	API-674, Second Edition
Configuration	Horizontal Quintuplex Plunger
Number of Plungers	5
Stroke Length	8.0 Inches
Frame Load Rating	30,000 lbs
Forged Fluid Cylinder Pressure Rating	10,000 psi
Cast Fluid Cylinder Pressure Rating	3,000 psi
Pump Weight (Average)	13,000 lbs
Intermittent Duty Speed Rating	300 RPM
Continuous Duty Speed Rating	210 RPM
API-674 Max Recommended Speed	210 RPM
Minimum Speed *	100 RPM
Mechanical Efficiency	90%
Lubrication System (Standard)	Splash, Gravity Return
Lubrication System (Optional)	Pressurized, Motor or Crank Driven
Lube Oil Capacity	40 Gallons
Lube Oil Type	SAE 30
Maximum Fluid Temperature	200 °F (400 °F Capability)
Minimum Fluid Temperature	-20 °F (-50 °F Capability)
Valve Types	Disc Valves, Abrasion Resistant Valves

* Slower RPM can be achieved with the addition of a pressurized lubrication system

Forged Fluid End Material	Cast Fluid End Material
A105 Carbon Steel	Ductile Iron
A350-LF2 Carbon Steel	Nickel Aluminum Bronze
316L Stainless Steel	316L Stainless Steel
2205 Duplex Stainless Steel	2205 Duplex Stainless Steel
Alloy Steel	

* Special Materials available on request

Standard Connection Sizes	Suction	Discharge
Q3214-Q3220	4.0	3.0
Q3214-Q3224	6.0	3.0
Q3226-Q3234	8.0	4.0
Q3236-Q3240	10.0	6.0
Q3242-Q3250	12.0	6.0

* NPT Connections Available

* Consult us for specific exceptions to API-674 and NACE standards.

* Consult us for any application where inlet pressures will exceed 10% of rated discharge pressures.

* Horsepower based on 90% mechanical efficiency. Actual application horsepower requirements can be calculated using the equation: $BHP = (GPM * PSI) / (1714 * 0.90)$

* Direction of rotation is the top of the crankshaft towards the fluid head.

Q32 Performance Table

Pump Model	Plunger Diameter (in)	Displacement (GAL/REV)	Pressure (PSI)	Pump Capacity (GPM) @ Input Speed (RPM)					
				100 RPM	150RPM	200RPM	210RPM	250RPM	300RPM
Q3214	1.750	0.4165	10,000	42	62	83	87	104	125
Q3216	2.000	0.5440	9,550	54	82	109	114	136	163
Q3218	2.250	0.6885	7,500	69	103	138	145	172	207
Q3220	2.500	0.8500	6,125	85	128	170	179	213	255
Q3222	2.750	1.0285	5,025	103	154	206	216	257	309
Q3224	3.000	1.2240	4,250	122	184	245	257	306	367
Q3226	3.250	1.4365	3,620	144	215	287	302	359	431
Q3228	3.500	1.6660	3,125	167	250	333	350	417	500
Q3230	3.750	1.9125	2,720	191	287	383	402	478	574
Q3232	4.000	2.1760	2,390	218	326	435	457	544	653
Q3234	4.250	2.4565	2,110	246	368	491	516	614	737
Q3236	4.500	2.7540	1,890	275	413	551	578	689	826
Q3238	4.750	3.0685	1,690	307	460	614	644	767	921
Q3240	5.000	3.4000	1,530	340	510	680	714	850	1,020
Q3242	5.250	3.7485	1,390	375	562	750	787	937	1,125
Q3244	5.500	4.1140	1,260	411	617	823	864	1,029	1,234
Q3246	5.750	4.4965	1,160	450	674	899	944	1,124	1,349
Q3248	6.000	4.8960	1,060	490	734	979	1,028	1,224	1,469
Q3250	6.250	5.3125	980	531	797	1,063	1,116	1,328	1,594

FMC Bolt-on Gearbox Ratios Available

6.17 : 1

7.30 : 1

9.57 : 1

* Pump capacities shown are based on 100% volumetric efficiency.

* FMC recommends NPSHa (available) exceeds NPSHr (required) by 5 feet of water.

* Take special consideration when calculating NPSHa. Recalculate NPSHa after pump model has been selected for more accurate values.

* NPSHr values are in feet of water. If you are pumping a different liquid than water, convert the required NPSHa from water to the liquid being pumped by dividing the published NPSHr value by the specific gravity of the liquid being pumped.

FMC published NPSHr values are based on test data collected on specific pumps at the factory and are estimated values. Actual NPSHr values for an ordered pump can only be determined by a factor test. For NPSH critical applications, contact the factory for additional information and request a NPSHr test performed on your pump before shipment.

Q32 Plunger Pump Data

700 BHP Continuous Duty (1,000 BHP Intermittent Duty)

Forged Pump Engineering Dimensional Outline

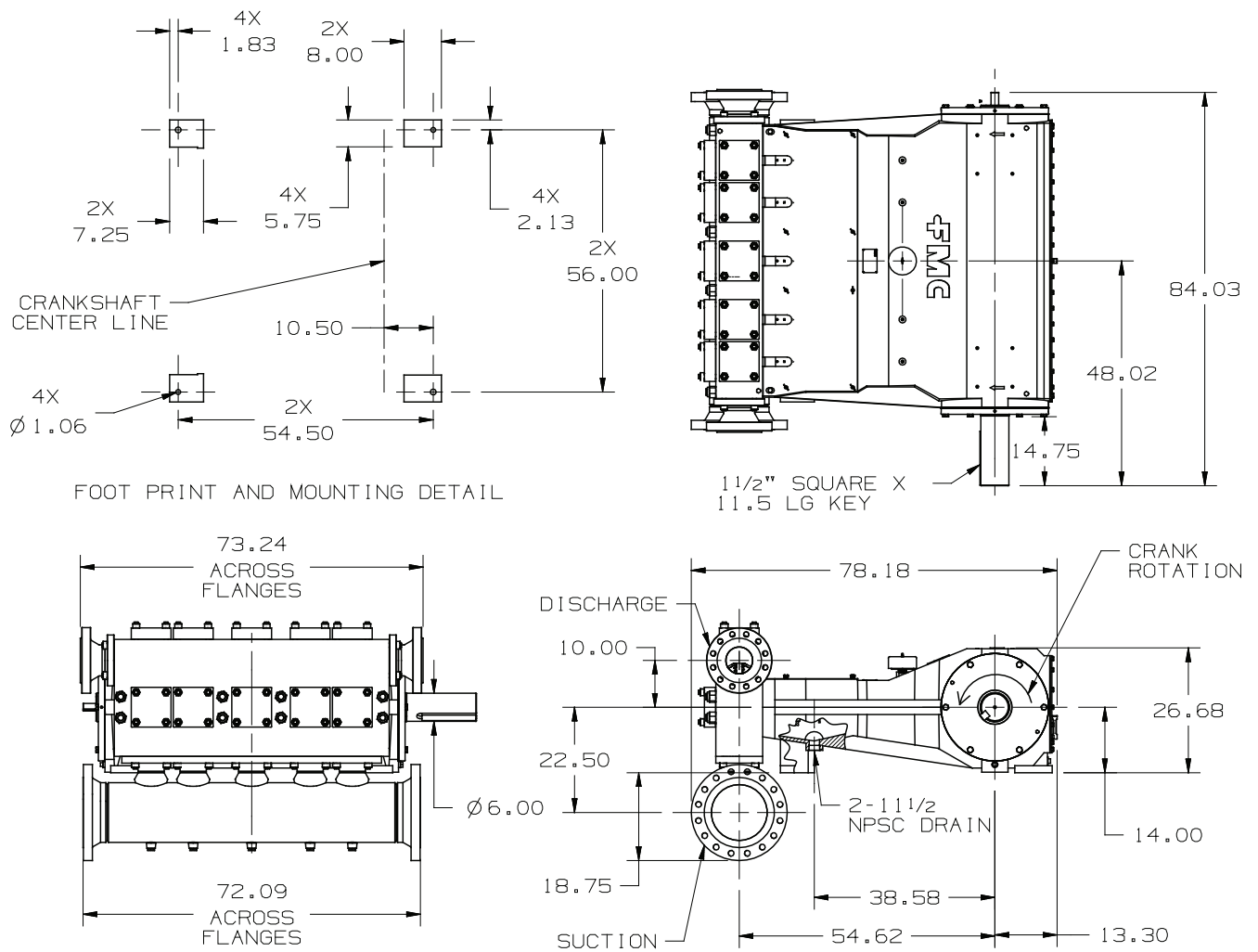

Q32 Plunger Pump Data

700 BHP Continuous Duty (1,000 BHP Intermittent Duty)

Cast Pump Engineering Dimensional Outline

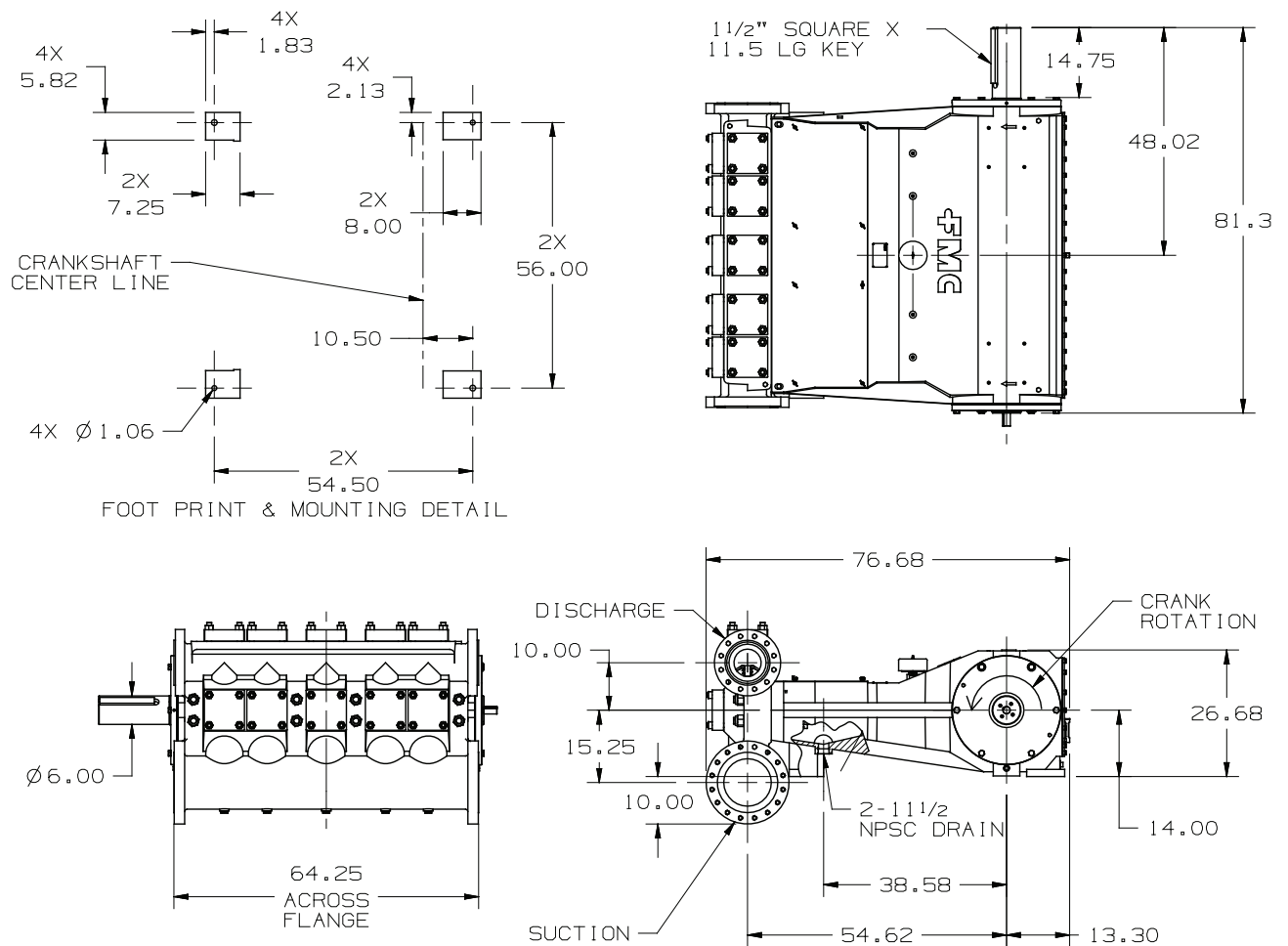

- Dimensions shown are for general sizing purposes and should not be used of construction. Contact FMC for actual dimensions of pump ordered.
- FMC reserves the right to modify this information without prior notice.
- Pump drawing dimensions in inches.