

FMC Technologies

Q18 Plunger Pump Data

265 BHP Continuous Duty (325 BHP Intermittent Duty)

Forged ISO Drawing

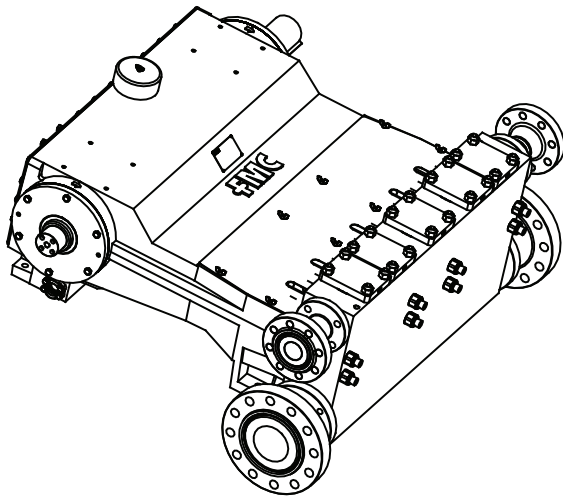

Cast ISO Drawing

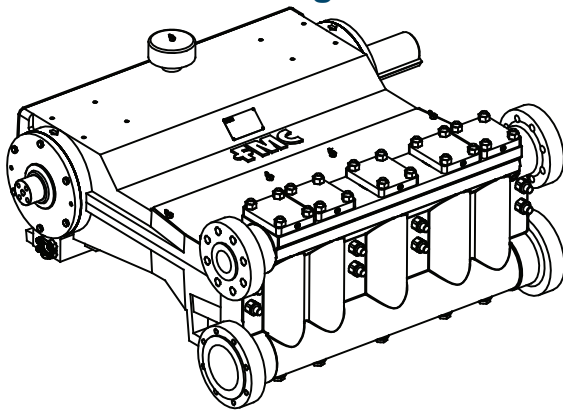

Specifications

Pump Model	Q18
Design Standard	API-674, Second Edition
Configuration	Horizontal Quintuplex Plunger
Number of Plungers	5
Stroke Length	4.5 Inches
Frame Load Rating	12,500 lbs
Forged Fluid Cylinder Pressure Rating	10,000 psi
Cast Fluid Cylinder Pressure Rating	3,000 psi
Pump Weight (Average)	4,500 lbs
Intermittent Duty Speed Rating	400 RPM
Continuous Duty Speed Rating	330 RPM
API-674 Max Recommended Speed	330 RPM
Minimum Speed *	100 RPM
Mechanical Efficiency	90%
Lubrication System (Standard)	Splash, Gravity Return
Lubrication System (Optional)	Pressurized, Motor or Crank Driven
Lube Oil Capacity	16 Gallons
Lube Oil Type	SAE 30
Maximum Fluid Temperature	200 °F (400 °F Capability)
Minimum Fluid Temperature	-20 °F (-50 °F Capability)
Valve Types	Disc Valves, Abrasion Resistant Valves

* Slower RPM can be achieved with the addition of a pressurized lubrication system

Forged Fluid End Material	Cast Fluid End Material
A105 Carbon Steel	Ductile Iron
A350-LF2 Carbon Steel	Nickel Aluminum Bronze
316L Stainless Steel	316L Stainless Steel
2205 Duplex Stainless Steel	2205 Duplex Stainless Steel
Alloy Steel	

* Special Materials available on request

Standard Connection Sizes	Suction	Discharge
Q1811-Q1818	4.0	2.0
Q1820-Q1828	6.0	3.0
Q1830-Q1836	8.0	4.0

* NPT Connections Available

* Consult us for specific exceptions to API-674 and NACE standards.

* Consult us for any application where inlet pressures will exceed 10% of rated discharge pressures.

* Horsepower based on 90% mechanical efficiency. Actual application horsepower requirements can be calculated using the equation: $BHP = (GPM * PSI) / (1714 * 0.90)$

* Direction of rotation is the top of the crankshaft towards the fluid head.

Q18 Performance Table

Pump Model	Plunger Diameter (in)	Displacement (GAL/REV)	Pressure (PSI)	Pump Capacity (GPM) @ Input Speed (RPM)					
				100 RPM	200RPM	300RPM	330RPM	350RPM	400RPM
Q1811	1.375	0.1446	8,400	15	29	44	48	51	58
Q1812	1.500	0.1721	7,100	17	34	52	57	60	69
Q1814	1.750	0.2343	5,200	23	47	70	77	82	94
Q1816	2.000	0.3060	4,000	31	61	92	101	107	122
Q1818	2.250	0.3873	3,100	39	78	116	128	136	155
Q1820	2.500	0.4781	2,500	48	96	143	158	167	191
Q1822	2.750	0.5785	2,100	58	116	174	191	202	231
Q1824	3.000	0.6885	1,800	69	138	207	227	241	275
Q1826	3.250	0.8080	1,500	81	162	242	267	283	323
Q1828	3.500	0.9371	1,300	94	187	281	309	328	375
Q1830	3.750	1.0758	1,100	108	215	323	355	377	430
Q1832	4.000	1.2240	1,000	122	245	367	404	428	490
Q1834	4.250	1.3818	900	138	276	415	456	484	553
Q1836	4.500	1.5491	800	155	310	465	511	542	620

Q18 NPSHr values for Disc Valves with 2-springs

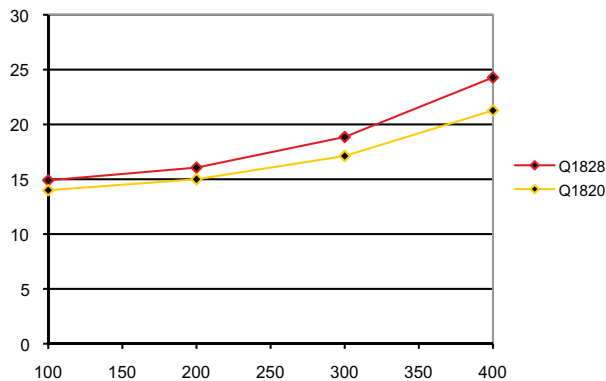

Q18 NPSHr values for AR Valves with 1-springs

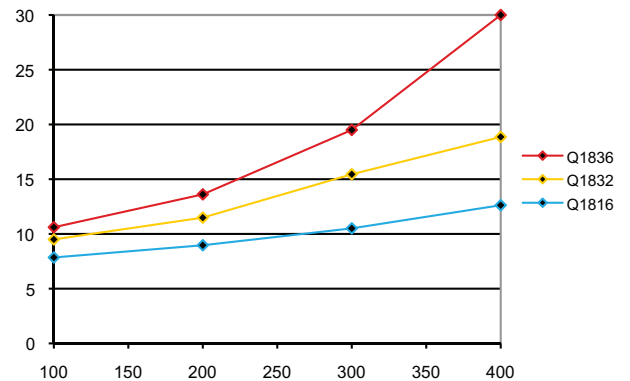

* Pump capacities shown are based on 100% volumetric efficiency.
 * FMC recommends NSPHa (available) exceeds NPSHr (required) by 5 feet of water.
 * Take special consideration when calculating NPSHa. Recalculate NPSHa after pump model has been selected for more accurate values.
 * NPSHr values are in feet of water. If you are pumping a different liquid than water, convert the required NPSHa from water to the liquid being pumped by dividing the published NPSHr value by the specific gravity of the liquid being pumped.
 FMC published NPSHr values are based on test data collected on specific pumps at the factory and are estimated values. Actual NPSHr values for an ordered pump can only be determined by a factor test. For NPSH critical applications, contact the factory for additional information and request a NPSHr test performed on your pump before shipment.

Q18 Plunger Pump Data

265 BHP Continuous Duty (325 BHP Intermittent Duty)

Forged Pump Engineering Dimensional Outline

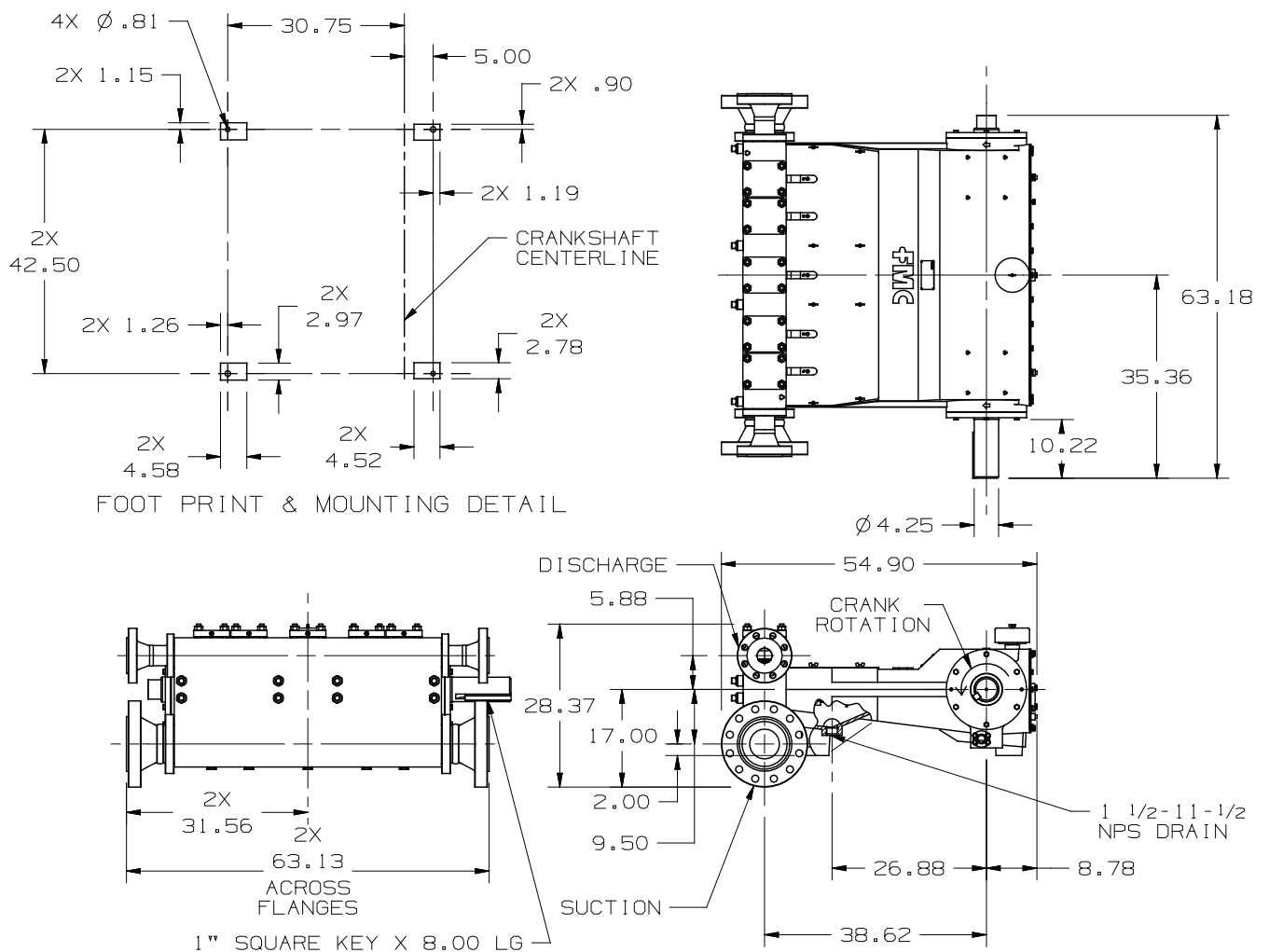

Q18 Plunger Pump Data

265 BHP Continuous Duty (325 BHP Intermittent Duty)

Cast Pump Engineering Dimensional Outline

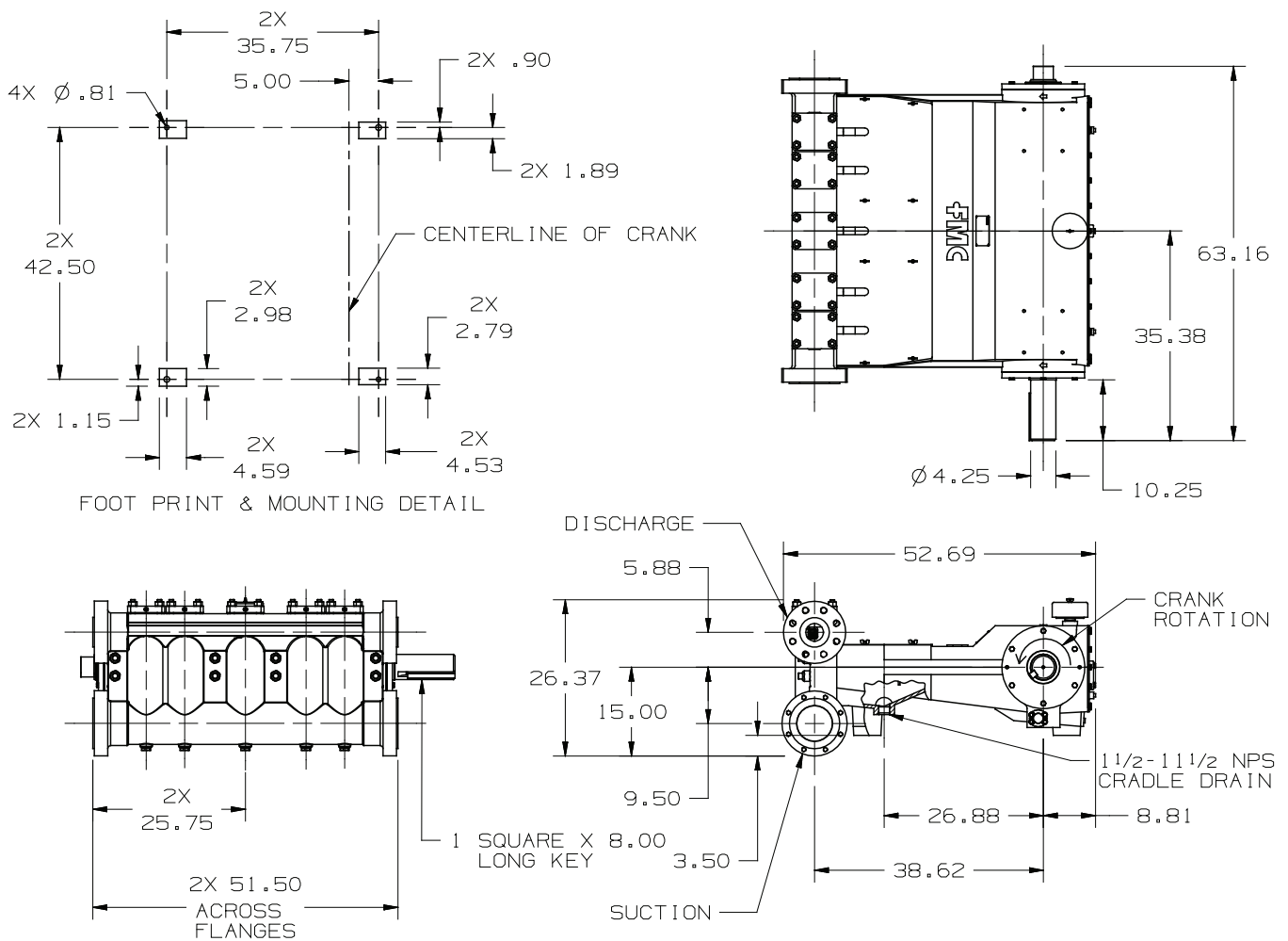

- Dimensions shown are for general sizing purposes and should not be used of construction. Contact FMC for actual dimensions of pump ordered.
- FMC reserves the right to modify this information without prior notice.
- Pump drawing dimensions in inches.