

FMC Technologies

M14 Plunger Pump Data

88 BHP Continuous Duty (104 BHP Intermittent Duty)

Forged ISO Drawing

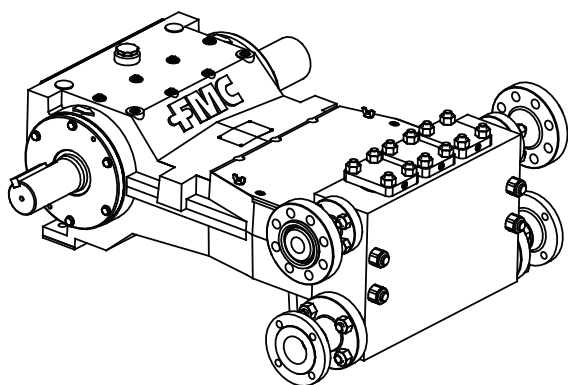

Cast ISO Drawing

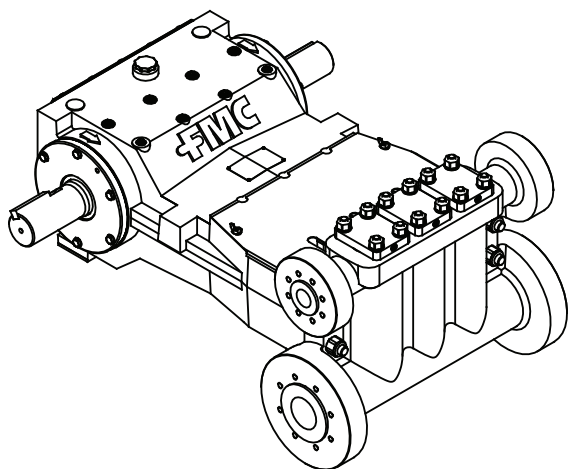

Specifications

Pump Model	M14
Design Standard	API-674, Second Edition
Configuration	Horizontal Triplex Plunger
Number of Plungers	3
Stroke Length	3.5 Inches
Frame Load Rating	8,000 lbs
Forged Fluid Cylinder Pressure Rating	10,000 psi
Cast Fluid Cylinder Pressure Rating	3,000 psi
Pump Weight (Average)	1,800 lbs
Intermittent Duty Speed Rating	425 RPM
Continuous Duty Speed Rating	375 RPM
API-674 Max Recommended Speed	375 RPM
Minimum Speed *	100 RPM
Mechanical Efficiency	90%
Lubrication System (Standard)	Splash, Gravity Return
Lubrication System (Optional)	Pressurized, Motor Driven
Lube Oil Capacity	6.5 Gallons
Lube Oil Type	SAE 30
Maximum Fluid Temperature	200 °F (400 °F Capability)
Minimum Fluid Temperature	-20 °F (-50 °F Capability)
Valve Types	Disc Valves, Abrasion Resistant Valves

* Slower RPM can be achieved with the addition of a pressurized lubrication system

Forged Fluid End Material	Cast Fluid End Material
A105 Carbon Steel	Ductile Iron
A350-LF2 Carbon Steel	Nickel Aluminum Bronze
316L Stainless Steel	316L Stainless Steel
2205 Duplex Stainless Steel	2205 Duplex Stainless Steel
Alloy Steel	

* Special Materials available on request

Standard Connection Sizes	Suction	Discharge
M1408-M1420	3.0	2.0
M1418-M1432	4.0	2.0
M1428-M1432	4.0	3.0

* NPT Connections Available

* Consult us for specific exceptions to API-674 and NACE standards.

* Consult us for any application where inlet pressures will exceed 10% of rated discharge pressures.

* Horsepower based on 90% mechanical efficiency. Actual application horsepower requirements can be calculated using the equation: $BHP = (GPM * PSI) / (1714 * 0.90)$

* Direction of rotation is the top of the crankshaft towards the fluid head.

M14 Performance Table

Pump Model	Plunger Diameter (in)	Displacement (GAL/REV)	Maximum Pressure (PSI)	Pump Capacity (GPM) @ Input Speed (RPM)						
				100 RPM	200 RPM	300RPM	350RPM	375RPM	400RPM	425RPM
M1408	1.000	0.0357	10,000	3.6	7.1	10.7	12.5	13.4	14.3	15.2
M1410	1.250	0.0558	6,500	5.6	11.2	16.7	19.5	20.9	22.3	23.7
M1412	1.500	0.0803	4,500	8.0	16.1	24.1	28.1	30.1	32.1	34.1
M1414	1.750	0.1093	3,300	10.9	21.9	32.8	38.3	41	43.7	46.5
M1416	2.000	0.1428	2,500	14.3	28.6	42.8	50.0	53.6	57.1	60.7
M1418	2.250	0.1807	2,000	18.1	36.1	54.2	63.2	67.8	72.3	76.8
M1420	2.500	0.2231	1,600	22.3	44.6	66.9	78.1	83.7	89.2	94.8
M1422	2.750	0.2700	1,350	27	54	81	95	101	108	115
M1424	3.000	0.3213	1,150	32.1	64.3	96.4	112	120	129	137
M1426	3.250	0.3771	1,000	37.7	75.4	113	132	141	151	160
M1428	3.500	0.4373	825	43.7	87.5	131	153	164	175	186
M1430	3.750	0.5020	725	50.2	100	151	176	188	201	213

M14 NPSHr values for AR Valves with 1-spring

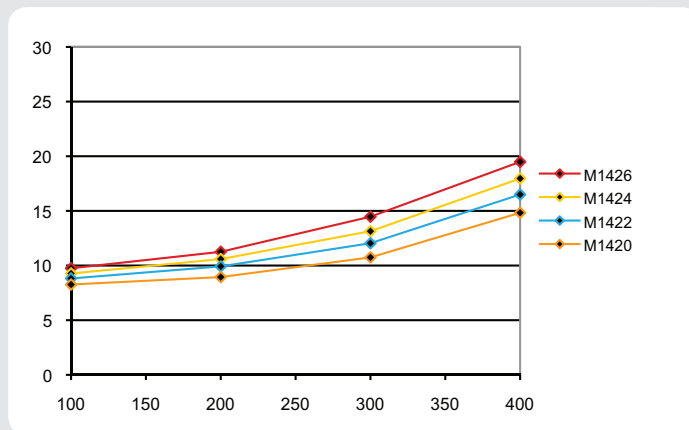

- * Pump capacities shown are based on 100% volumetric efficiency.
 - * FMC recommends NSPHa (available) exceeds NPSHr (required) by 5 feet of water.
 - * Take special consideration when calculating NSPHa. Recalculate NSPHa after pump model has been selected for more accurate values.
 - * NPSHr values are in feet of water. If you are pumping a different liquid than water, convert the required NSPHa from water to the liquid being pumped by dividing the published NSPHr value by the specific gravity of the liquid being pumped.
- FMC published NPSHr values are based on test data collected on specific pumps at the factory and are estimated values. Actual NPSHr values for an ordered pump can only be determined by a factor test. For NPSH critical applications, contact the factory for additional information and request a NPSHr test performed on your pump before shipment.

M14 Plunger Pump Data

88 BHP Continuous Duty (104 BHP Intermittent Duty)

Forged Pump Engineering Dimensional Outline

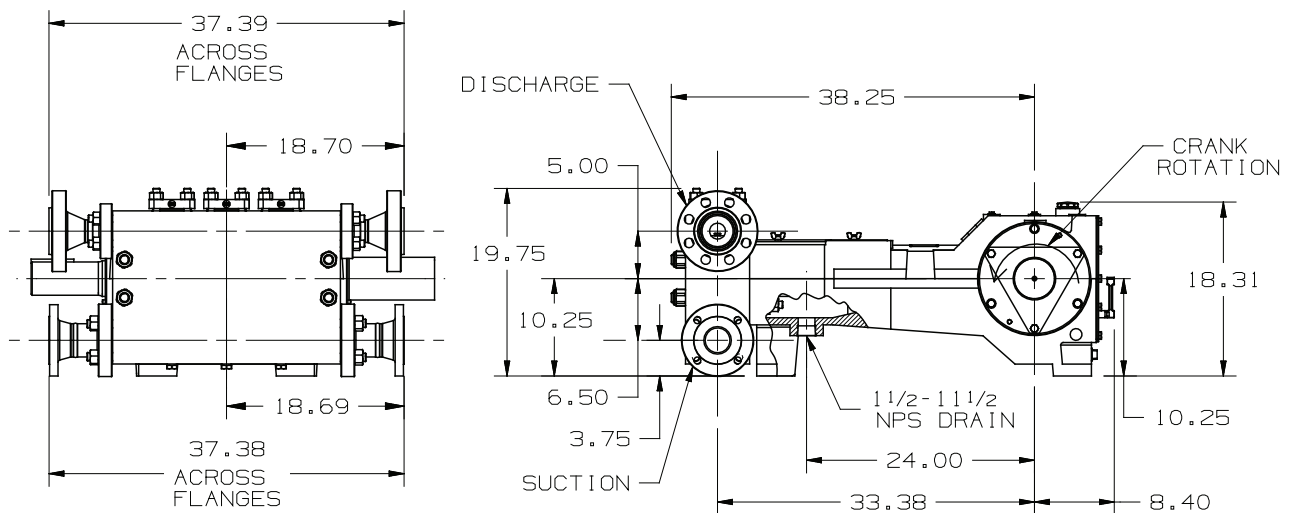
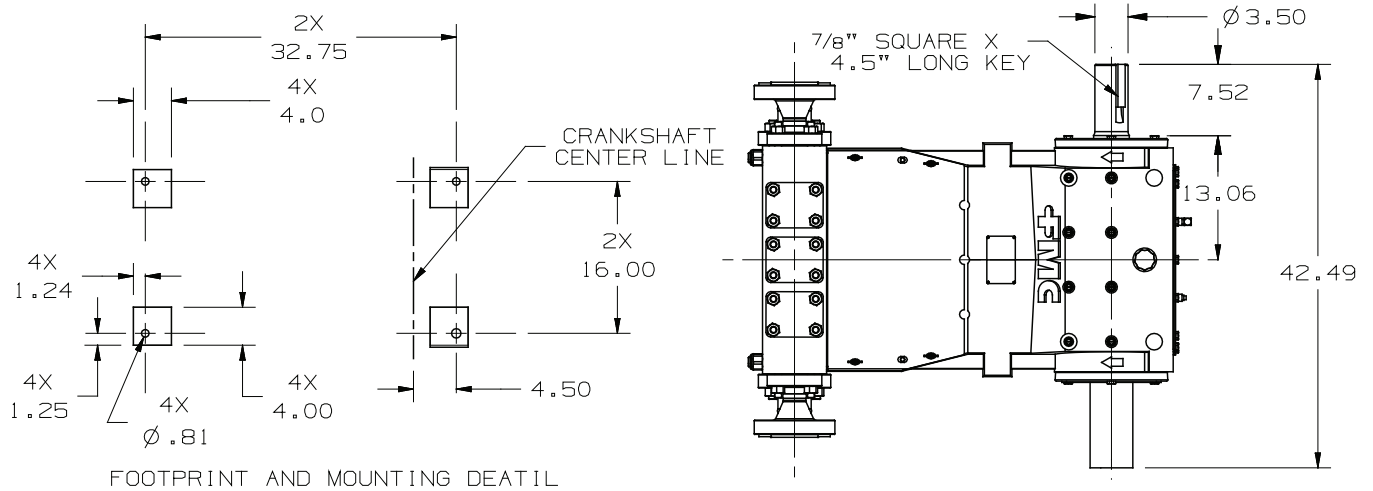

M14 Plunger Pump Data

88 BHP Continuous Duty (104 BHP Intermittent Duty)

Cast Pump Engineering Dimensional Outline

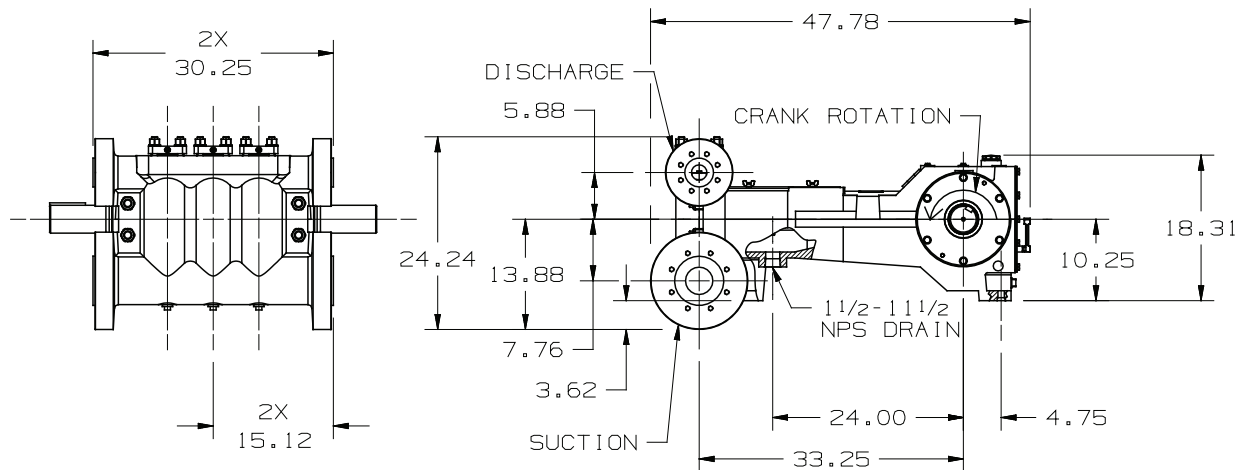
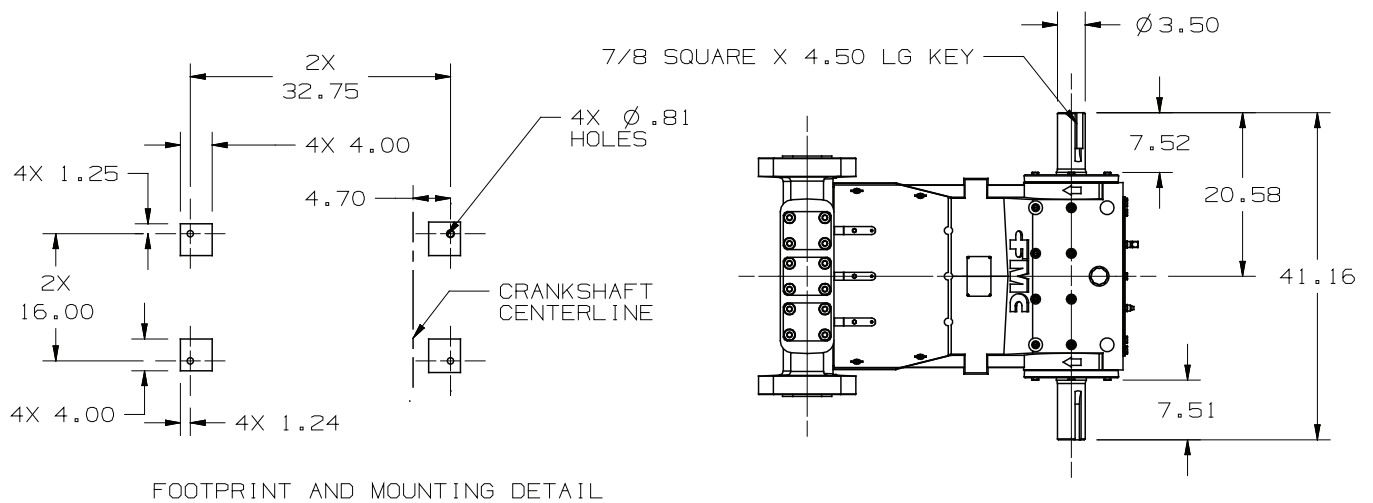

- Dimensions shown are for general sizing purposes and should not be used of construction. Contact FMC for actual dimensions of pump ordered.
- FMC reserves the right to modify this information without prior notice.
- Pump drawing dimensions in inches.